

Eliminate Measurement Errors and Achieve the Greatest Accuracy Using a DMM

Overview

When making measurements with a **digital multimeter (DMM)**, common errors such as signal interference, external noise, and internal current leakage will cause measurement errors. Understanding the root cause of these errors will help you eliminate and achieve the greatest accuracy possible using a DMM. This white paper covers several sources of system cabling and DC voltage measurement errors and the solutions to get the accuracy you need.

Learn more from this white paper on how to tackle the following measurement challenges while using a DMM to measure DC:

- common mode rejection
- noise caused by injected current
- loading errors due to input resistance
- loading errors because of input bias current

System Cabling Errors

Radio frequency interference

Most instruments measuring voltage can generate false readings in the presence of large, high-frequency signal sources such as nearby radio and television transmitters, computer monitors, and cell phones. Unwanted high-frequency energy can potentially couple to the multimeter through the system cabling. You reduce the interference by minimizing the exposure of the system cabling to high-frequency RF sources. Figure 1 shows a common mode choke used in system cabling to attenuate RFI emissions — in applications that are susceptible to RFI radiating from the multimeter.

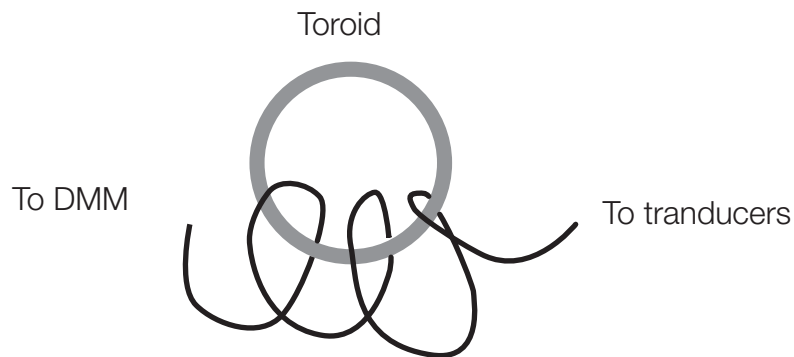

Figure 1. Using a toroid as a common mode choke in the system cabling

Thermal EMF errors

Thermoelectric voltages, the most common source of error in low-level voltage measurements, are generated when circuit connections use dissimilar metals at different temperatures. Each metal-to-metal junction forms a thermocouple, which creates a voltage proportional to the junction temperature. It is a best practice to implement the necessary precautions to minimize thermocouple voltages and temperature variations in low-level voltage measurements. The best connections use copper-to-copper crimped connections. Figure 2 shows common thermoelectric voltages for connections between dissimilar metals.

Copper-to-	Approx. $\mu\text{V}/^\circ\text{C}$
Copper	< 0.3
Gold	0.5
Silver	0.5
Brass	3
Beryllium copper	5
Aluminum	5
Kovar or Alloy 42	40
Silicon	500
Copper oxide	1000
Cadmium tin solder	0.2
Tin lead solder	5

Figure 2. List of thermoelectric voltages for connections between copper and various dissimilar metals

Noise caused by magnetic fields

When making measurements near magnetic fields, taking precautionary steps to avoid inducing voltages in the measurement connections is necessary. Induced voltage occurs by the movement of the input connection wiring in a fixed magnetic field, or by a varying magnetic field. An unshielded, poorly dressed input wire moving in the earth's magnetic field can generate several millivolts. The varying magnetic field around the AC power line can also induce voltages up to several hundred millivolts. Use caution when working near conductors carrying large electrical currents.

Where possible, route cabling away from magnetic fields. These fields are commonly present around electric motors, generators, televisions, and computer monitors. When operating near magnetic fields, you must confirm that the input wiring has a proper strain relief and is secure. Use twisted-pair connections to the multimeter to reduce noise in the pickup loop area or dress the wires close together.

Noise caused by ground loops

When you measure voltages in circuits where the multimeter and the device-under-test (DUT) are both referenced to a common earth ground, a ground loop is formed. Figure 3 shows that any voltage difference between the two ground reference points (V_{ground}) causes a current to flow through the LO measurement leads. This causes errors, such as noise and offset voltage (usually powerline related), added to the measured voltage.

The most effective method to eliminate ground loops is to maintain the multimeter's isolation from earth ground; do not connect the input terminals to the ground. If the multimeter must be earth referenced, be sure to connect it and the DUT using the same common earth ground point. This process will reduce or eliminate any voltage difference between the devices. Also, always connect both the multimeter and DUT to the same electrical outlet to reduce ground loops.

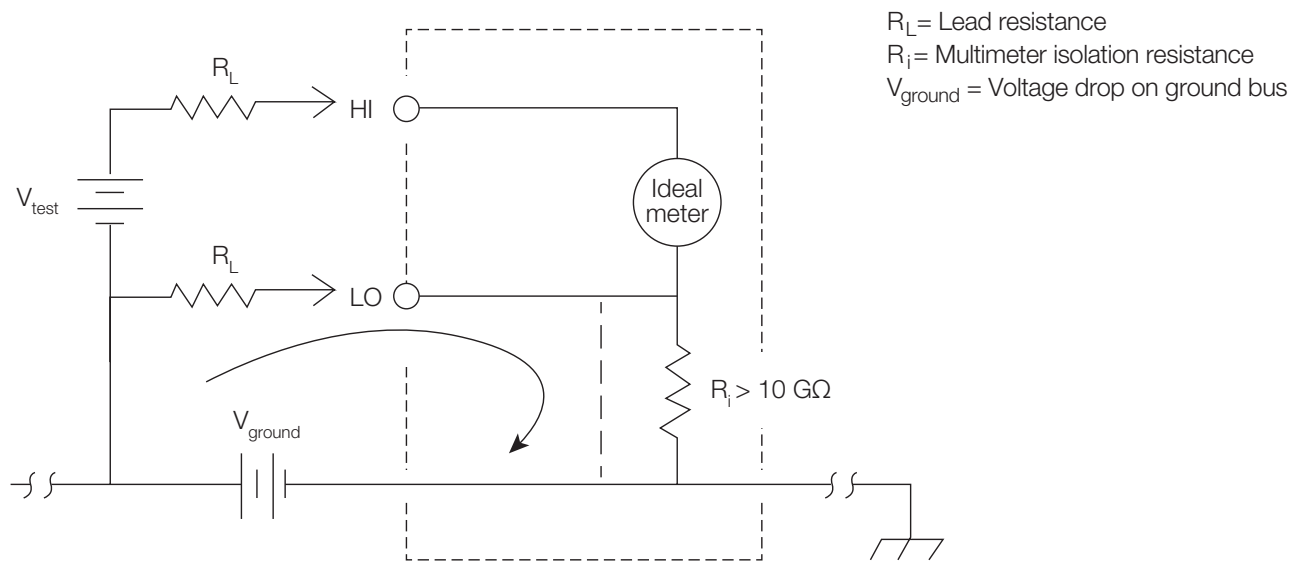

Figure 3. Example of how an earth ground loop forms

DC Voltage Measurement Errors

Common mode rejection

Ideally, a multimeter isolates completely from earth ground referenced circuits. Figure 4 shows there is, however, always a finite resistance and capacitance between the multimeter's input LO terminal and the earth ground. This can cause errors when you measure low voltages that are floating relative to earth ground.

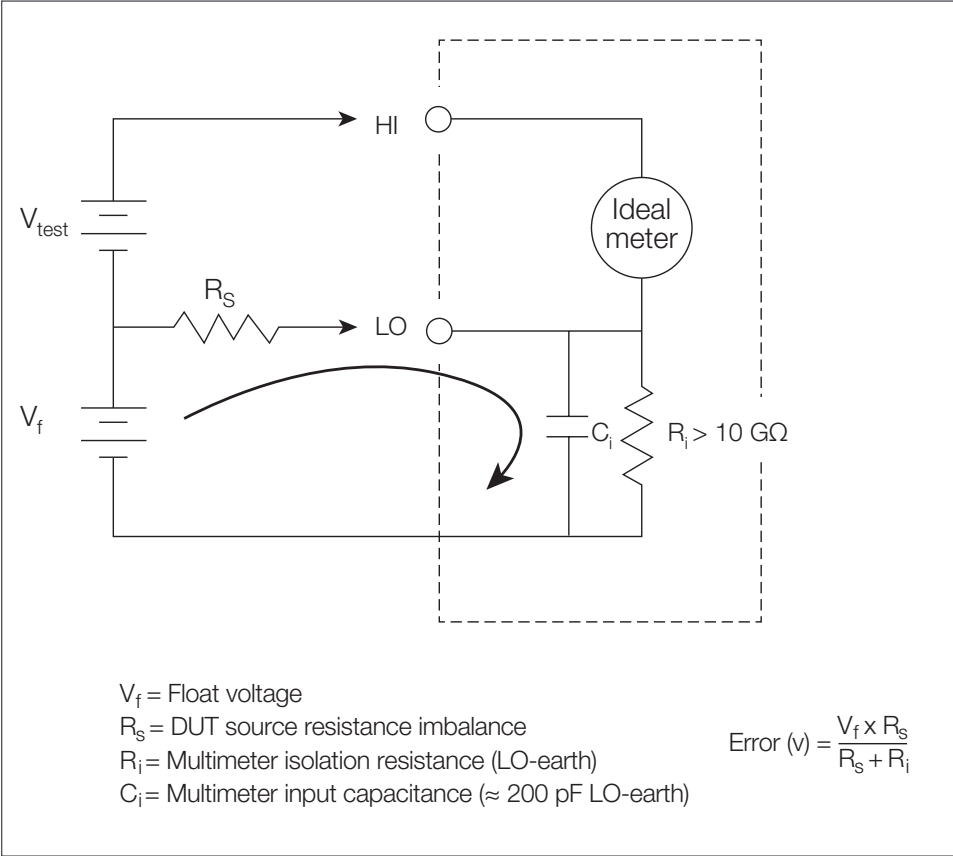

Figure 4. Diagram showing finite resistance between the DMM's input LO terminal and to earth ground

Noise caused by injected current

Residual capacitances in the multimeter's power transformer can cause small currents to flow from the LO terminal to earth ground. The frequency of the injected current is the power line frequency or possibly harmonics of the power line frequency. Figure 5 shows that the injected current is dependent upon the power line configuration and frequency.

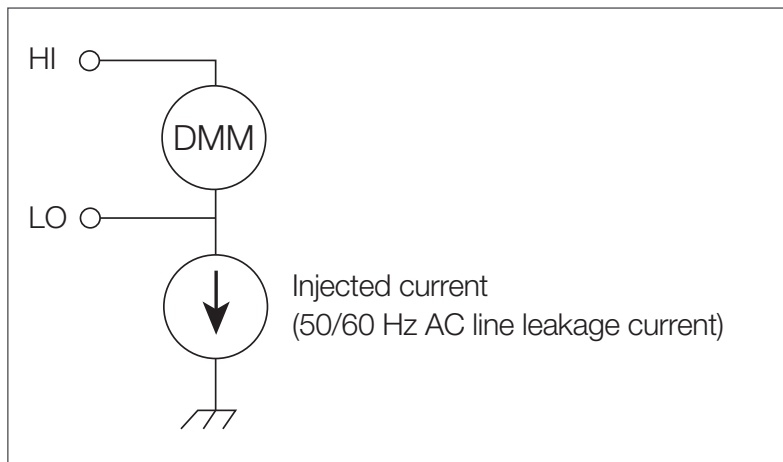

Figure 5. Injected current introduced by the DMM's LO terminal to earth ground

Figure 6 shows the injected current flows from the earth ground connection provided by the circuit to the LO terminal of the DMM from connection A — adding no noise to the measurement. However, with connection B, the injected current flows through resistor R — adding noise to the measurement. With connection B, higher values of R will compound the problem.

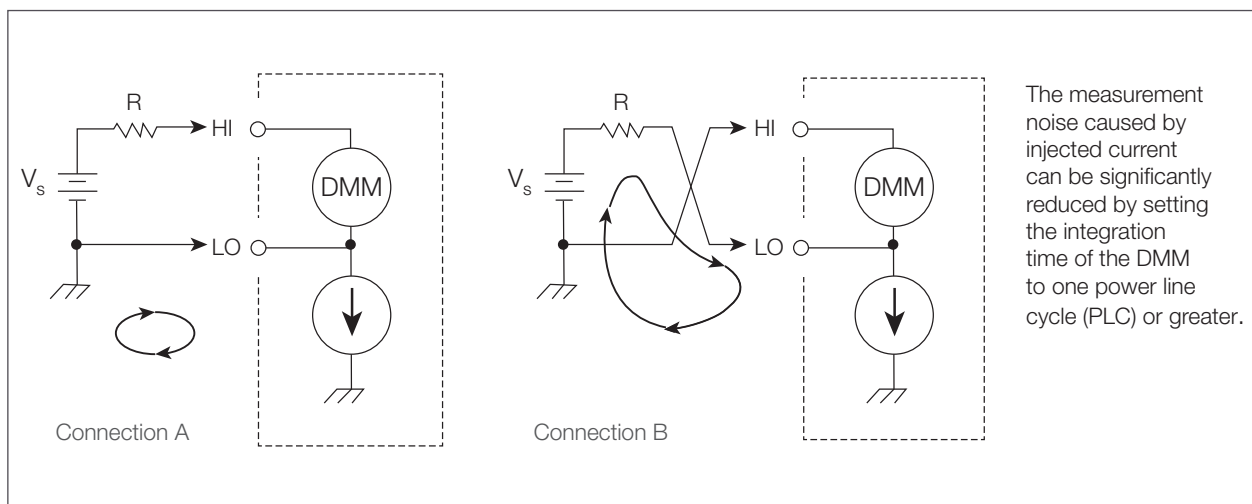

Figure 6. Example of how injected current adds noise to the measurement

Loading errors due to input resistance

Measurement loading errors occur when the resistance of the DUT is a considerable percentage of the multimeter's input resistance; Figure 7 shows this error source. To reduce the effects of loading errors, and to minimize noise pick up, set the DMM's input resistance to greater than 10 GΩ for the 100 mVdc, 1 Vdc, and 10 Vdc ranges. The input resistance remains at 10 MΩ for the 100 Vdc and 1000 Vdc ranges.

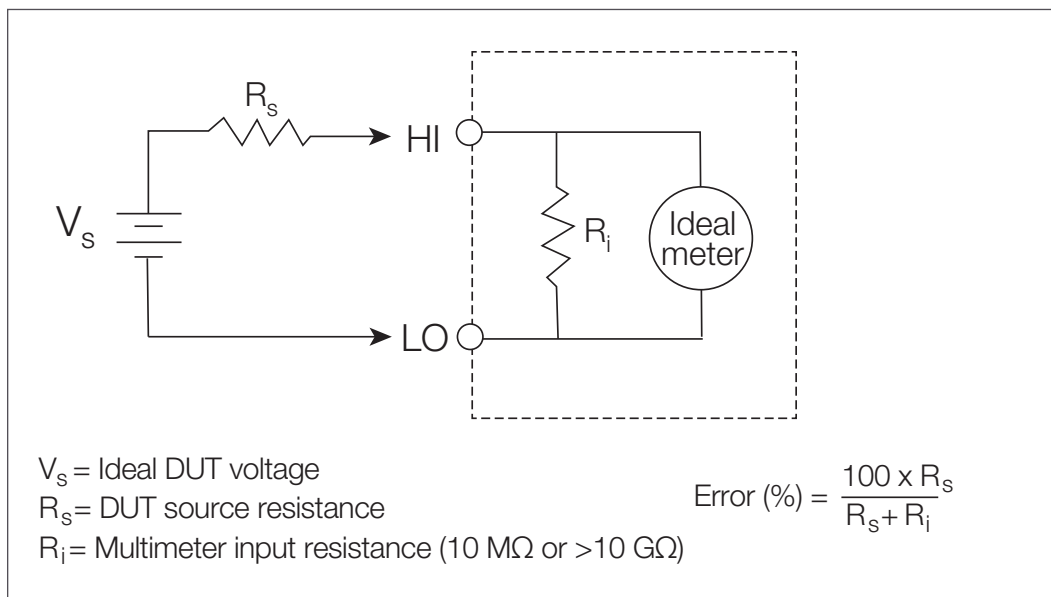

Figure 7. Example of the effects of loading errors due to input resistance

Loading errors due to input bias current

The multimeter's input capacitance will "charge up" due to input bias currents when the terminals are open-circuited (if the input resistance is 10 GΩ). The multimeter's measuring circuitry exhibits approximately 30 pA of input bias current for ambient temperatures from 0 to 30 °C. Bias current will double for every 8 °C change in ambient temperature above 30 °C. Figure 8 shows this current generates small voltage offsets dependent upon the source resistance of the DUT. This effect becomes evident for a source resistance of greater than 100 kΩ, or when the multimeter's operating temperature is significantly higher than 30 °C.

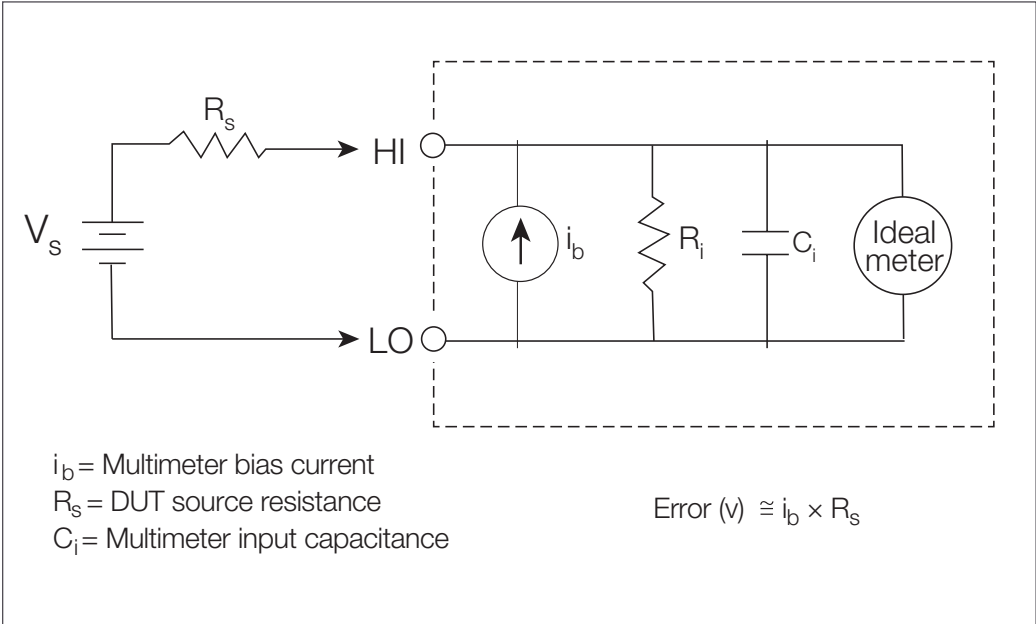

Figure 8. Example showing the effects of loading errors due to input bias current

Conclusion

Modern DMMs such as the Keysight 34460 and 34470 Truevolt Series have many features to help protect you from many common sources of error. When making low-level or precise measurements, you need visibility of sources that contribute to measurement errors.

Environmental conditions — such as changes in temperature, RF signals, and electromagnetic fields — will have a significant impact on the quality of your DMM measurements. Once you optimize the measurement environment, proper cabling can significantly reduce measurement errors. You can easily calculate the remaining sources of error and add this number to the measurement uncertainty.

Learn more about Keysight's 34460 and 34470 Truevolt Series DMMs, please visit <https://www.keysight.com/us/en/products/digital-multimeters-dmm/truevolt-series-multimeters.html>.



Keysight enables innovators to push the boundaries of engineering by quickly solving design, emulation, and test challenges to create the best product experiences. Start your innovation journey at www.keysight.com.



This information is subject to change without notice. © Keysight Technologies, 2002 - 2022, Published in USA, November 11, 2022, 5988-5511EN